

SAFETY, HEALTH AND ENVIRONMENTAL INFORMATION	
IN ADDITION TO THE HAZARDS/RISKS NORMALLY ASSOCIATED WITH THE TYPES OF WORK DETAILED ON THIS DRAWING, NOTE THE FOLLOWING	
<b>CONSTRUCTION</b> C1. NONE IDENTIFIED.	
<b>MAINTENANCE / CLEANING</b> M1. NONE IDENTIFIED	
<b>DECOMMISSIONING / DEMOLITION</b> D1. NONE IDENTIFIED	
IT IS ASSUMED THAT ALL WORKS WILL BE CARRIED OUT BY A COMPETENT CONTRACTOR WORKING, WHERE APPROPRIATE, TO AN APPROVED METHOD STATEMENT	

- NOTES:
- ALL DIMS IN METRES UNLESS OTHERWISE STATED.
  - ALL TIMBER FENCE POSTS, TO HAVE CONCRETE FOUNDATIONS IN ACCORDANCE WITH HCD H3
  - WHERE THE FENCE FORMS A BOUNDARY BETWEEN THE HIGHWAY AND PRIVATE PROPERTY, THE RAILS SHALL BE FIXED TO THE PRIVATE PROPERTY SIDE, UNLESS OTHERWISE STATED.

- KEY:
- PROPOSED RED LINE BOUNDARY AND PROPOSED HIGHWAY BOUNDARY
  - PROPOSED POST AND THREE RAIL MCHW H15 AND HEDGE. REFER TO LANDSCAPING DRAWINGS A29-CAP-HPN-00-DR-C-0239 FOR HEDGE DETAILS
  - 3.0m WEATHERED STEEL ACOUSTIC FENCING REFER TO DRG A29-CAP-HPN-00-DR-C-0183 AND 0184 FOR DETAILS
  - GATE REFER TO MCHW H17  
GATE NO.1 WIDTH 4.5M, HEIGHT 1.175M  
GATE NO.2 WIDTH 4.5M, HEIGHT 1.175M  
GATE NO.3 WIDTH 4.5M, HEIGHT 1.175M
  - FT 1 BADGER MESH FENCING 1.1m HIGH, TO COMPLY TO MCHW H46 MESH TO BE BURIED 300MM DEEP AND RETURNED 300MM AND FIXED TO POST AND THREE RAIL FENCE. THE FENCING TO EXTEND AS SHOWN ON THE PLAN EITHER SIDE OF THE WILDLIFE CROSSING POINT
  - PROPOSED POST AND THREE RAIL MCHW H15
  - PROPOSED CLOSE BOARD FENCE PANELS TO MATCH EXISTING
  - TEMPORARY HOARDING FENCE WITH GATE

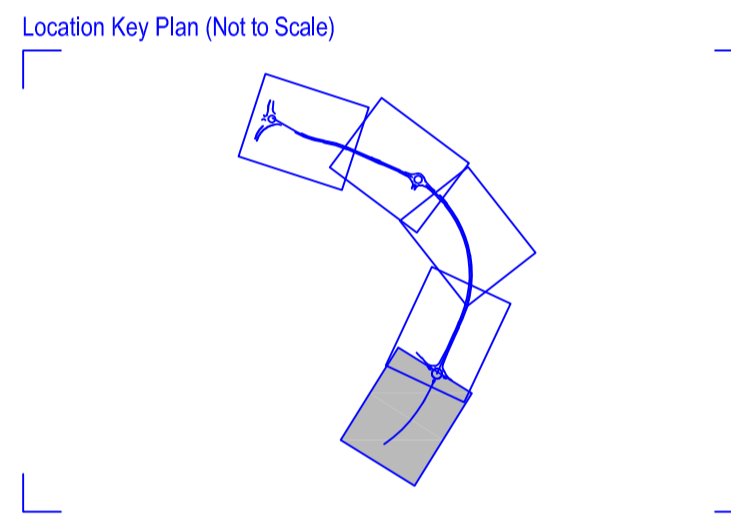

Rev	Drawn	Checked	App'd	Description	Date
P04	AS	KS	AB	KEY BADGER FENCE HEIGHT ADDED	10.06.22
P03	JB	KS	AB	KEY AMENDED	25.02.22
P02	JM	KS	AB	SCALE BAR ADDED	13.01.22
P01	KS	KS	AB	FIRST ISSUE	05.05.21

Purpose of Issue  
**For Planning** **S0**

Classification  
**Public**



Project  
**A29 Realignment Scheme**

Drawing  
**Fencing Layout**  
**Sheet 5 of 5**

Scale @ A1	Drawn	Checked	Approved
1:500	KS	KS	AB

Project No.	Date
CS099505	05-05-21

Drawing Identifier	revision
Project - Originator - Zone - Level - File Type - Role - Number <b>A29-CAP-HPN-00-DR-C-0262</b>	<b>P04</b>



Capita House, Wood Street, East Grinstead, RH19 1UU  
01342 327161  
www.capitaproperty.co.uk  
Capita Property and Infrastructure Ltd.

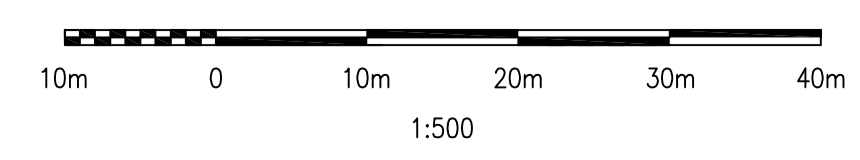

P:\Hwy\A29\0262\0262.dwg