

SAFETY, HEALTH AND ENVIRONMENTAL INFORMATION	
IN ADDITION TO THE HAZARDS/RISKS NORMALLY ASSOCIATED WITH THE TYPES OF WORK DETAILED ON THIS DRAWING, NOTE THE FOLLOWING	
CONSTRUCTION	C1. EXISTING SERVICES ALONG FONTWELL AVENUE.
MAINTENANCE / CLEANING	M1. NONE IDENTIFIED
DECOMMISSIONING / DEMOLITION	D1. NONE IDENTIFIED
IT IS ASSUMED THAT ALL WORKS WILL BE CARRIED OUT BY A COMPETENT CONTRACTOR WORKING, WHERE APPROPRIATE, TO AN APPROVED METHOD STATEMENT	

- NOTES:
- ALL DIMS IN METRES UNLESS OTHERWISE STATED.
 - ALL TIMBER FENCE POSTS, TO HAVE CONCRETE FOUNDATIONS IN ACCORDANCE WITH HCD H3
 - WHERE THE FENCE FORMS A BOUNDARY BETWEEN THE HIGHWAY AND PRIVATE PROPERTY, THE RAILS SHALL BE FIXED TO THE PRIVATE PROPERTY SIDE, UNLESS OTHERWISE STATED.
- KEY:
- PROPOSED RED LINE BOUNDARY AND PROPOSED HIGHWAY BOUNDARY
 - PROPOSED POST AND THREE RAIL MCHW H15 AND HEDGE. REFER TO LANDSCAPING DRAWING A29-CAP-HPN-00-DR-C-0239 FOR HEDGE DETAILS
 - 3.0m ACOUSTIC FENCING REFER TO DRG A29-CAP-HPN-00-DR-C-0183 AND 184 FOR DETAILS
 - GATE REFER TO MCHW H17 GATE NO.1 WIDTH 4.5M, HEIGHT 1.175M GATE NO.2 WIDTH 4.5M, HEIGHT 1.175M GATE NO.3 WIDTH 4.5M, HEIGHT 1.175M
 - FT1 BADGER MESH FENCING 1.1m HIGH, TO COMPLY TO MCHW H46 MESH TO BE BURIED 300MM DEEP AND RETURNED 300MM AND FIXED TO POST AND THREE RAIL FENCE. THE FENCING TO EXTEND AS SHOWN ON THE PLAN EITHER SIDE OF THE WILDLIFE CROSSING POINT
 - PROPOSED POST AND THREE RAIL MCHW H15
 - PROPOSED CLOSE BOARD FENCE PANELS TO MATCH EXISTING
 - TEMPORARY HOARDING FENCE WITH GATE

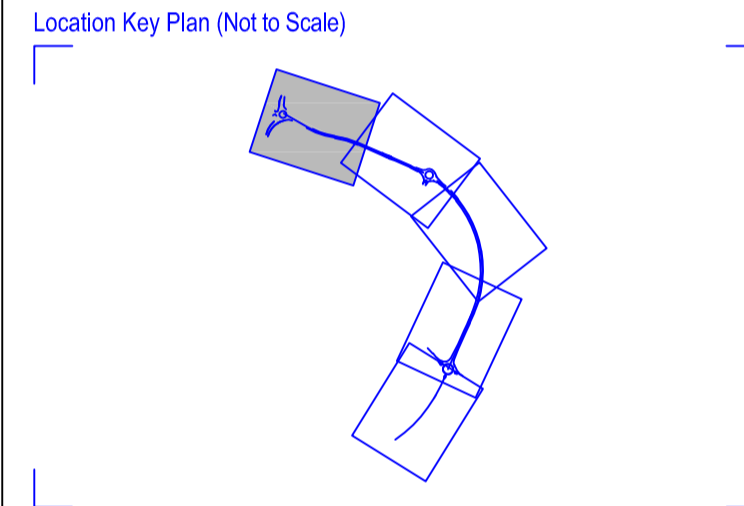

Rev	Drawn	Checked	App'd	Description	Date
P05	AS	KS	AB	KEY BADGER FENCE HEIGHT ADDED	10.06.22
P04	JB	KS	AB	BADGER FENCING EXTENDED AND KEY AMENDED	25.02.22
P03	JB	KS	KS	POST AND RAIL ADDED TO THE SOUTH SIDE	14.02.22
P02	JM	KS	AB	SCALE BAR ADDED	13.01.22
P01	KS	KS	AB	FIRST ISSUE	05.05.21

Purpose of Issue
For Planning S0

Classification
Public



Project
A29 Realignment Scheme

Drawing
Fencing Layout
Sheet 1 of 5

Scale @ A1	Drawn	Checked	Approved
1:500	KS	KS	AB

Project No. **CS099505** Date **05-05-21**

Drawing Identifier **A29-CAP-HPN-00-DR-C-0258** BS1192 Compliant revision **P05**



Capita House, Wood Street, East Grinstead, RH19 1UU
 01342 327161
 www.capitaproperty.co.uk
 Capita Property and Infrastructure Ltd.

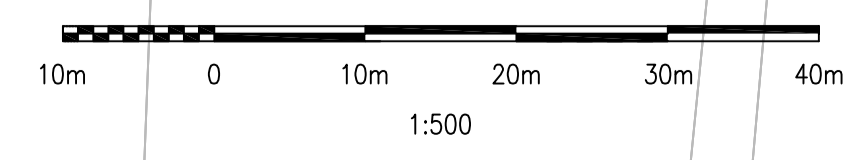

PHD Date: 15/05/2022 12:56:38