

LANDSCAPING KEY:		FENCING KEY:	
	REDLINE BOUNDARY		TXX TREE PRESERVATION ORDER - INDICATIVE LOCATION ONLY
	EXISTING VEGETATION - TO BE RETAINED AS MUCH AS POSSIBLE. EXTENTS OF CLEARANCE IN THESE AREAS IS TO BE AGREED ON SITE WITH OVERSEEING ORGANISATION'S SITE SUPERVISOR		ROOT PROTECTION AREA - INDICATIVE LOCATION ONLY
	TEMPORARY USE LAND. TO BE REINSTATED LAND BACK TO EXISTING		SHARED USE FOOTWAY / CYCLEWAY BOUND SURFACE COURSE - ASPHALT CONCRETE
	TEMPORARY USE LAND. TO BE LEFT IN A TIDY STATE. NO NEED TO REINSTATE		FOOTWAY BOUND SURFACE COURSE - ASPHALT CONCRETE
	WOODLAND EDGE SW1 TOPSOIL 300MM - 450MM		CARRIAGEWAY HRA SURFACE COURSE
	SCRUB SW2 TOPSOIL 300MM - 450MM		TRAFFIC ISLAND BOUND SURFACE COURSE - ASPHALT CONCRETE
	SPECIMEN TREE SW3		POND ACCESS TRACKS UNBOUND SUB BASE TYPE 1
	SPECIMEN SHRUBS		GRASSCRETE
	WILDFLOWER MEADOW GRASS MIX EM3 TOPSOIL 150MM. SOIL MIXING (VERGES) AND INVERSION (LARGER AREAS).		HEDGE
	WETLAND GRASS MIX EM8 TOPSOIL 150MM		CONSTRUCTION EXCLUSION ZONE - WHEREBY AVOID VEGETATION STRIP ALL TOGETHER AND CONSTRUCTION WORKS ACCESS IS EXCLUDED
	SUBMERGED AND FLOATING PLANTS FOR PONDS		RESTRICTED WORKING ZONE - WHEREBY EXISTING VEGETATION IS ONLY STRIPPED WHERE ABSOLUTELY NECESSARY. WORKS WITHIN THESE AREAS TO BE SUBJECT TO TASK/ LOCATION SPECIFIC ARBORICULTURAL METHOD STATEMENT. THE AMS FOR EACH TO BE DEVELOPED DURING CONSTRUCTION PLANNING. THE WORK METHODOLOGY IS TO BE AGREED WITH THE ECOW/ ARBORICULTURIST. TREE PROTECTION FENCING REQUIREMENTS TO THESE AREAS TO BE AGREED WITH ARBORICULTURIST AND ECOW on site.
	MARGINAL PLANTS FOR PONDS TOPSOIL 150MM		ROOT BARRIER EACH SIDE OF FILTER DRAIN
	PUBLIC RIGHT OF WAY SELF BINDING PATH GRAVEL		SWALE PLANTING PLAN 10NO. SALIX ALBA VAR. VITELLINA 'BRITZENSIS' 25NO. FILIPENDULA ULMARIA (MEADOW SWEET) AND 25NO. PURPLE LOOSESTRIFE (LYTHRUM SALICARIA) EACH SIDE
	WILDLIFE CROSSING		
	INDICATIVE LIGHTING COLUMN WITH REFERENCE LETTER FOR THE LIGHTING UNIT TYPE (INCLUDING HEIGHT) AS SHOWN IN THE LIGHTING PLANS INCLUDED IN APPENDIX 10.2 OF THE REVISED ES		

- NOTES:
- ALL DIMENSIONS ARE IN METRES UNLESS OTHERWISE STATED.
 - EARTHWORKS SIDE SLOPES ARE 1 IN 3 WHERE POSSIBLE. IN AREAS LIMITED BY LAND OR ENVIRONMENTAL RESTRICTIONS, STEEPER SLOPES HAVE BEEN GENERATED.
 - REFER TO DRAWING A29-CAP-HPN-00-DR-C-0132 FOR THE TYPICAL DETAIL FOR LIGHTING COLUMN BEHIND SHARED FOOTWAY / CYCLEWAY WITH LOCALISED WIDENED VERGE.
 - LIGHTING COLUMNS SET BACK 0.5M BEHIND THE FOOTWAY / CYCLEWAY.
 - REFER TO THE ECOLOGICAL MITIGATION PLAN FOR THE SCHEME ECOLOGICAL ENHANCEMENT MEASURES REQUIRED.

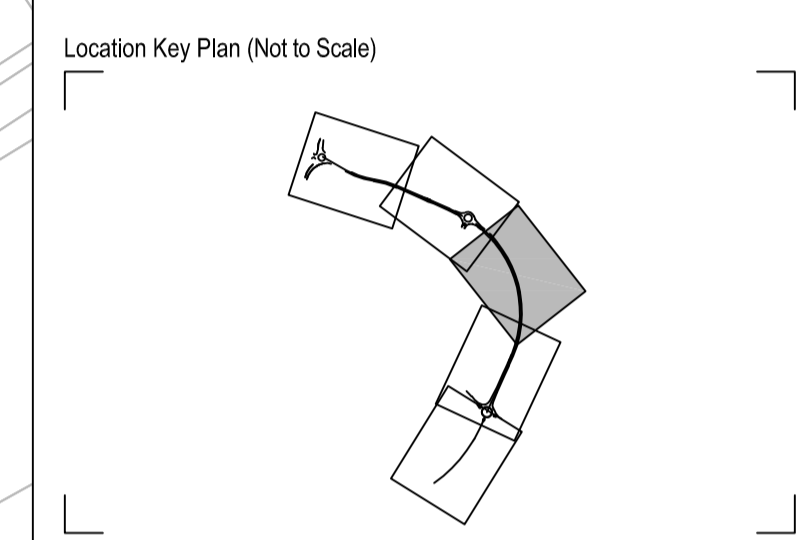

Rev	Drawn	Checked	App'd	Description	Date
P13	AS	KS	AB	2No. GAPS IN HEDGE AND SCRUB AREAS FILLED IN AND NOTE FOR ROOT BARRIER PROTECTION ADDED FOR THE DRAINAGE PIPES BENEATH BEHIND THE ACOUSTIC FENCE.	13.05.22
P12	JB	KS	KS	NOTE 5 ADDED AND KEY AMENDED	18.03.22
P11	AS	KS	AB	LANDSCAPING KEY AMENDED	10.03.22
P10	JB	KS	AB	POST AND FENCE ADDED TO THE WEST SIDE OF A29	25.02.22
P09	JB	KS	AB	LIGHTING LAYOUT UPDATED AND KEY AMENDED FOR SPECIMEN SHRUBS, HEDGE AND FENCE ADDED TO ENCLOSE LANDSCAPE AREA AND ORCHARD. LIGHTING COLUMNS OFFSET TO BE 0.5M FROM THE SHARED FOOTWAY / CYCLEWAY.	18.02.22
P08	KS	KS	AB	KEY UPDATED AND LABELS ADDED	10.12.21
P07	KS	KS	AB	REDLINE BOUNDARY UPDATED. LANDSCAPE AND FENCING DETAILS ADDED.	23.04.21
P06	JD	KS	AB	KEY UPDATED AND LABELS ADDED	30.03.21
P05	LR	KS	AB	LABELS AMENDED	21.10.20
P04	LR	KS	AB	HIGHWAY LAYOUT AND REDLINE BOUNDARY UPDATED	16.10.20
P03	PD	KS	AB	KEY ADDED	03.06.20
P02	LR	KS	AB	LABELS ADDED / AMENDED	28.08.20
P01	PD	DAH	KS	FIRST ISSUE	12.08.20

Purpose of Issue
For Planning S0

Classification
Public

Client
west Sussex County Council

Project
A29 Realignment Scheme

Logo: Jackson

Drawing
Site Plan Sheet 3 of 5

Scale @ A1	Drawn	Checked	Approved
1:500	PD	RP	KS

Project No. CS099505 Date 12.06.20

Drawing Identifier
Project - Originator - Zone - Level - File Type - Role - Number
A29-CAP-HPN-00-DR-C-0134 P13

CAPITA

Capita House, Wood Street, East Grinstead, RH19 1UU
01342 327161
www.capitaproperty.co.uk
Capita Property and Infrastructure Ltd.