

- NOTES:
- ALL DIMENSIONS ARE IN METRES UNLESS OTHERWISE STATED.
 - EARTHWORKS SIDE SLOPES ARE 1 IN 3 WHERE POSSIBLE. IN AREAS LIMITED BY LAND OR ENVIRONMENTAL RESTRICTIONS, STEEPER SLOPES HAVE BEEN GENERATED.
 - REFER TO DRAWING A29-CAP-HPN-00-DR-C-0132 FOR THE TYPICAL DETAIL FOR LIGHTING COLUMN BEHIND SHARED FOOTWAY/ CYCLEWAY WITH LOCALISED WIDENED VERGE.
 - LIGHTING COLUMNS SET BACK 0.5M BEHIND THE FOOTWAY/ CYCLEWAY.
 - REFER TO THE ECOLOGICAL MITIGATION PLAN FOR THE SCHEME ECOLOGICAL ENHANCEMENT MEASURES REQUIRED.

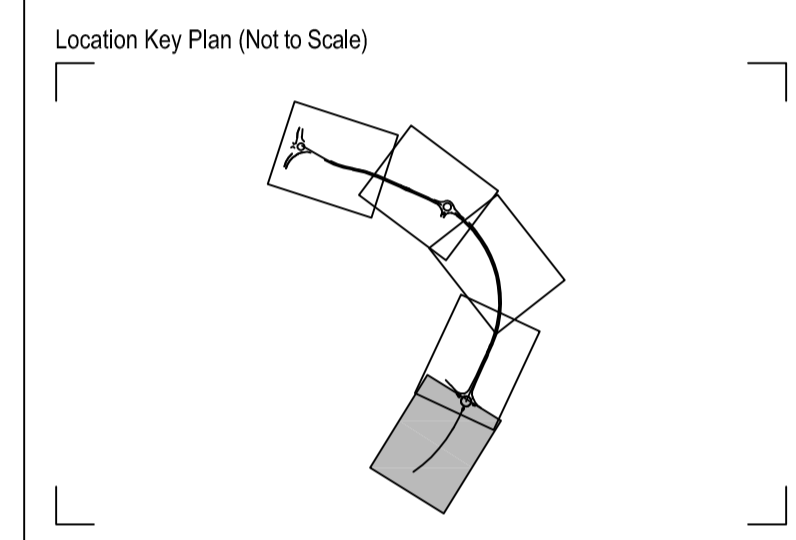

Rev	Drawn	Checked	App'd	Description	Date
P12	JB	KS	KS	NOTE 5 ADDED AND KEY AMENDED	18.03.22
P11	AS	KS	AB	LANDSCAPING KEY AMENDED	10.03.22
P10	JB	KS	AB	KEY AMENDED	25.02.22
P09	JB	KS	AB	KEY AMENDED	18.02.22
P08	KS	KS	AB	LIGHTING COLUMNS OFFSET TO BE 0.5M FROM THE SHARED FOOTWAY/ CYCLEWAY	10.12.21
P07	KS	KS	AB	KEY UPDATED AND LABELS ADDED	23.04.21
P06	JD	KS	AB	REDLINE BOUNDARY UPDATED, LANDSCAPE AND FENCING DETAILS ADDED, POND 4 LOCATION REVISD	30.03.21
P05	LR	KS	AB	HIGHWAY LAYOUT AND REDLINE BOUNDARY UPDATED	21.10.20
P04	LR	KS	AB	KEY AMENDED	16.10.20
P03	PD	KS	AB	KEY AMENDED	03.09.20
P02	LR	KS	AB	LABELS ADDED / AMENDED	28.06.20
P01	PD	DAH	KS	FIRST ISSUE	12.06.20

Purpose of Issue
For Planning S0

Classification
Public



Project
A29 Realignment Scheme

Drawing
Site Plan Sheet 5 of 5

Scale @ A1	Drawn	Checked	Approved
1:500	PD	DAH	KS

Project No. CS099505 Date 12.06.20

Drawing Identifier A29-CAP-HPN-00-DR-C-0136 revision P12



Capita House, Wood Street, East Grinstead, RH19 1UU
01342 327161
www.capitaproperty.co.uk
Capita Property and Infrastructure Ltd.

LANDSCAPING KEY:

- REDLINE BOUNDARY
- EXISTING VEGETATION - TO BE RETAINED AS MUCH AS POSSIBLE. EXTENTS OF CLEARANCE IN THESE AREAS IS TO BE AGREED ON SITE WITH OVERSEEING ORGANISATION'S SITE SUPERVISOR
- TEMPORARY USE LAND, TO BE REINSTATED LAND BACK TO EXISTING
- TEMPORARY USE LAND, TO BE LEFT IN A TIDY STATE. NO NEED TO REINSTATE
- WOODLAND EDGE SW1 TOPSOIL 300MM - 450MM
- SCRUB SW2 TOPSOIL 300MM - 450MM
- SPECIMEN TREE SW3
- SPECIMEN SHRUBS
- WILDFLOWER MEADOW GRASS MIX EM3 TOPSOIL 150MM. SOIL MIXING (VERGES) AND INVERSION (LARGER AREAS).
- WETLAND GRASS MIX EM8 TOPSOIL 150MM
- SUBMERGED AND FLOATING PLANTS FOR PONDS
- MARGINAL PLANTS FOR PONDS TOPSOIL 150MM
- PUBLIC RIGHT OF WAY SELF BINDING PATH GRAVEL
- WILDLIFE CROSSING
- INDICATIVE LIGHTING COLUMN WITH REFERENCE LETTER FOR THE LIGHTING UNIT TYPE (INCLUDING HEIGHT) AS SHOWN IN THE LIGHTING PLANS INCLUDED IN APENDIX 10.2 OF THE REVISED ES

FENCING KEY:

- PROPOSED POST AND THREE RAIL MCHW H15 AND HEDGE ON THE HIGHWAY SIDE.
- 3.0m ACOUSTIC FENCING REFER TO DRG A29-CAP-HPN-00-DR-C-0183 AND 0184 FOR DETAILS. CLIMBING PLANTS ON WEST SIDE.
- GATE REFER TO MCHW H17 GATE NO.1 WIDTH 4.5M, HEIGHT 1.175M GATE NO.2 WIDTH 4.5M, HEIGHT 1.175M GATE NO.3 WIDTH 4.5M, HEIGHT 1.175M
- FT1 BADGER MESH FENCING, TO COMPLY TO MCHW H46 MESH TO BE BURIED 300MM DEEP AND RETURNED 300MM AND FIXED TO POST AND THREE RAIL FENCE. THE FENCING TO EXTEND AS SHOWN ON THE PLAN EITHER SIDE OF THE WILDLIFE CROSSING POINT
- PROPOSED POST AND THREE RAIL MCHW H15
- PROPOSED CLOSE BOARD FENCE PANELS TO MATCH EXISTING
- TEMPORARY HOARDING FENCE WITH GATE
- PROPOSED FENCING - HALO SITE CLOSE BOARD FENCE PANELS WITH GREEN MESH SECURITY FENCE TO MATCH EXISTING HALO FENCING.
- EXISTING FENCING - HALO SITE 1.8M CLOSE BOARD FENCE PANELS INC GRAVEL BOARD WITH 2.4M CENTRE OF CONCRETE POSTS 2.3M GREEN MESH SECURITY FENCE PANELS WITH 3.3M CENTRE OF GREEN METAL POST. SUPPLIER PROCTER - PRO-MESH PANEL FENCING SYSTEMS

SWALE PLANTING PLAN
10NO. SALIX ALBA VAR. VITELLINA 'BRITZENSIS'
25NO. FILIPENDULA ULMARIA (MEADOW SWEET) AND 25NO. PURPLE LOOSESTRIFE (LYTHRUM SALICARIA) EACH SIDE

ROOT BARRIER EACH SIDE OF FILTER DRAIN

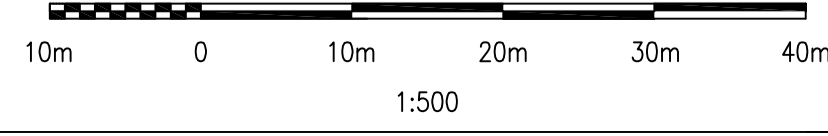

PH1 Date: 18/03/2022 16:47:47