

- KEY (Cont.):
- TREE PRESERVATION ORDER - INDICATIVE LOCATION ONLY
 - HIGHWAY BOUNDARY
 - TREES
 - CATEGORY A
 - CATEGORY B
 - CONFIRMED
 - HIGH
 - GROUPS
 - HEDGES
 - CATEGORY C
 - RS-XXX ROAD SIGN TO BE RETAINED
 - RS-XXX ROAD SIGN TO BE REMOVED
 - RS-XXX ROAD SIGN TO BE REMOVED TO STORE
 - RS-XXX ROAD SIGN TO BE RELOCATED

SAFETY, HEALTH AND ENVIRONMENTAL INFORMATION	
IN ADDITION TO THE HAZARDS/RISKS NORMALLY ASSOCIATED WITH THE TYPES OF WORK DETAILED ON THIS DRAWING, NOTE THE FOLLOWING	
CONSTRUCTION C1. EXISTING SERVICES IN THE NURSERY AREA INCLUDING 2No. ELECTRICITY SUBSTATIONS. C2. POTENTIAL BURIED UNEXPLODED ORDNANCE (UXO). C3. BUILDING DEMOLITION, UNKNOWN MATERIALS.	
MAINTENANCE / CLEANING NONE IDENTIFIED.	
DECOMMISSIONING / DEMOLITION NONE IDENTIFIED.	
IT IS ASSUMED THAT ALL WORKS WILL BE CARRIED OUT BY A COMPETENT CONTRACTOR WORKING IN ACCORDANCE WITH THE REQUIREMENTS OF AN APPROVED METHOD STATEMENT	

- NOTES:
- ALL DIMENSIONS IN METRES UNLESS OTHERWISE STATED
 - SITE CLEARANCE WORKS OUTSIDE OF HIGHWAY BOUNDARY ARE SUBJECT TO AGREEMENT FOR ACCESS FROM LAND OWNERS. WSCC IN CONSULTATION WITH LAND OWNERS
 - ALL SITE CLEARANCE WORKS IN AREAS CURRENTLY NOT OWNED BY WSCC ARE SUBJECT TO SUCCESSFUL LAND PURCHASE NEGOTIATION
 - THERE IS A REQUIREMENT TO APPOINT A BUILDING ARCHAEOLOGIST TO RECORD THE WALL PRIOR TO DEMOLITION TO AN APPROPRIATE HISTORIC ENGLAND LEVEL.
 - WHERE TREES ARE BEING REMOVED FROM SITE, LOGS ARE TO BE RETAINED FOR THE CREATION OF LOG PILES FOR REPTILE REFUGIA TO SERVE AS INVERTEBRATE HABITAT. REFER TO LANDSCAPE
 - ALL SITE CLEARANCE WORKS ARE TO BE UNDERTAKEN IN ACCORDANCE WITH THE AGREED CONSTRUCTION ENVIRONMENTAL MANAGEMENT PLAN.
 - UPDATED GROUND LEVEL INSPECTION OF VEGETATION PRIOR TO REMOVAL TO CHECK FOR BAT ROOST POTENTIAL.
 - TREES OF LOW SUITABILITY CAN BE SOFT FELLED FOLLOWING AT HEIGHT INSPECTION OF POTENTIAL ROOST FEATURES TO CONFIRM ABSENCE.
 - TREES OF MODERATE - HIGH SUITABILITY WILL BE SUBJECT TO CLIMBING INSPECTION. FURTHER DETAILS INCLUDED IN CEMP.
 - ECOLOGICAL GROUND SURVEY REQUIRED PRIOR TO WORKS TO DETERMINE EUROPEAN PROTECTED SPECIES LICENCE REQUIREMENTS AND ASSOCIATED EXCLUSION ZONES.

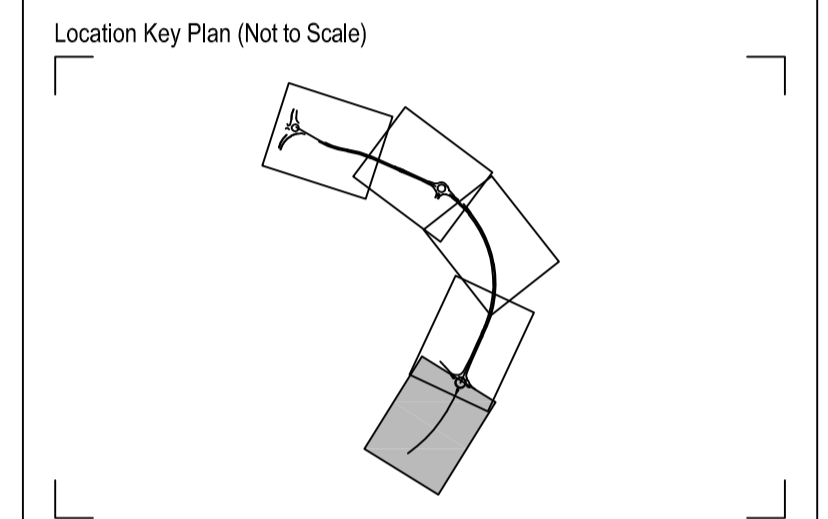

Rev	Drawn	Checked	App'd	Description	Date
P01	AS	KS	AB	FIRST ISSUE	23/04/2021

Purpose of Issue: **For Planning** S0

Classification: **Public**

Client:

Project: **A29 Realignment Scheme**

Drawing: **Site Clearance Layout Sheet 5 of 5**

Scale @ A1	Drawn	Checked	Approved
1:500	CY	GL	KS

Project No.	Date
CS099505	23-04-21

Drawing Identifier: **A29-CAP-HPN-00-DR-C-0250** revision **P01**

CAPITA

Capita House, Wood Street, East Grinstead, RH19 1UJ
01342 327161
www.capitaproperty.co.uk
Capita Property and Infrastructure Ltd.