

- NOTES:
1. ALL DIMENSIONS IN METRES UNLESS OTHERWISE STATED
  2. SITE CLEARANCE WORKS OUTSIDE OF HIGHWAY BOUNDARY ARE SUBJECT TO AGREEMENT FOR ACCESS FROM LAND OWNERS. WSCC IN CONSULTATION WITH LAND OWNERS
  3. ALL SITE CLEARANCE WORKS IN AREAS CURRENTLY NOT OWNED BY WSCC ARE SUBJECT TO SUCCESSFUL LAND PURCHASE NEGOTIATION
  4. THERE IS A REQUIREMENT TO APPOINT A BUILDING ARCHAEOLOGIST TO RECORD THE WALL PRIOR TO DEMOLITION TO AN APPROPRIATE HISTORIC ENGLAND LEVEL
  5. WHERE TREES ARE BEING REMOVED FROM SITE, LOGS ARE TO BE RETAINED FOR THE CREATION OF LOG PILES FOR REPTILE REFUGIA TO SERVE AS INVERTEBRATE HABITAT. REFER TO LANDSCAPE
  6. ALL SITE CLEARANCE WORKS ARE TO BE UNDERTAKEN IN ACCORDANCE WITH THE AGREED CONSTRUCTION ENVIRONMENTAL MANAGEMENT PLAN.
  7. UPDATED GROUND LEVEL INSPECTION OF VEGETATION PRIOR TO REMOVAL TO CHECK FOR BAT ROOST POTENTIAL.
  8. TREES OF LOW SUITABILITY CAN BE SOFT FELLED FOLLOWING AT HEIGHT INSPECTION OF POTENTIAL ROOST FEATURES TO CONFIRM ABSENCE.
  - TREES OF MODERATE - HIGH SUITABILITY WILL BE SUBJECT TO CLIMBING INSPECTION. FURTHER DETAILS INCLUDED IN CEMP.
  9. ECOLOGICAL GROUND SURVEY REQUIRED PRIOR TO WORKS TO DETERMINE EUROPEAN PROTECTED SPECIES LICENCE REQUIREMENTS AND ASSOCIATED EXCLUSION ZONES.

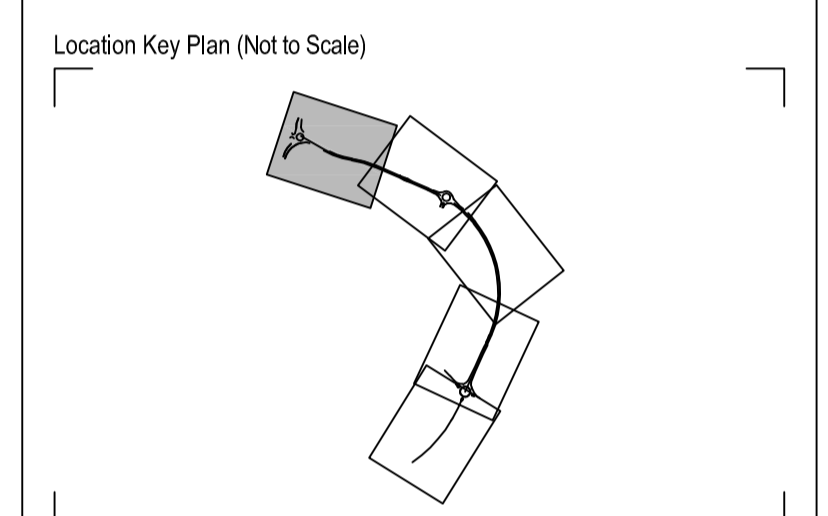

P01	AS	KS	AB	FIRST ISSUE	23/04/2021
Rev	Drawn	Checkd	Apprd	Description	Date
Purpose of Issue					
For Planning					S0
Classification					
Public					
Client					
west sussex county council		Jackson			

Project					
A29 Realignment Scheme					
Drawing					
Site Clearance Layout Sheet 1 of 5					
Scale @ A1					
1:500	Drawn	Checked	Approved		
	CY	GL	KS		
Project No.					
CS099505				Date	23.04.2021
Drawing Identifier					
A29-CAP-HPN-00-DR-C-246					851192 Consultant revision P01

**CAPITA**

Capita House, Wood Street, East Grinstead, RH19 1UJ  
 01342 327161  
 www.capitaproperty.co.uk  
 Capita Property and Infrastructure Ltd.

SAFETY, HEALTH AND ENVIRONMENTAL INFORMATION	
IN ADDITION TO THE HAZARDS/RISKS NORMALLY ASSOCIATED WITH THE TYPES OF WORK DETAILED ON THIS DRAWING, NOTE THE FOLLOWING	
<b>CONSTRUCTION</b>	
C1.	EXISTING SERVICES ALONG FORTWELL AVENUE.
C2.	COAL TAR PRESENT IN FABRIC OF EXISTING CARRIAGEWAY.
C3.	POTENTIAL BURIED UNEXPLODED ORDNANCE (LUXO).
C4.	INTERFACE WITH EXISTING TRAFFIC & PEDESTRIANS WHEN IMPLEMENTING PHASED WORKS, TEMP DIVERSIONS & TM.
C5.	BUILDING DEMOLITION, UNKNOWN MATERIALS.
<b>MAINTENANCE / CLEANING</b>	
NONE IDENTIFIED.	
<b>DECOMMISSIONING / DEMOLITION</b>	
NONE IDENTIFIED.	
IT IS ASSUMED THAT ALL WORKS WILL BE CARRIED OUT BY A COMPETENT CONTRACTOR WORKING, WHERE APPROPRIATE, TO AN APPROVED METHOD STATEMENT	

KEY (Cont.):

	TREE PRESERVATION ORDER - INDICATIVE LOCATION ONLY	<b>G</b>	GROUPS
	HIGHWAY BOUNDARY	<b>H</b>	HEDGES
	TREES	<b>C</b>	CATEGORY C
	CATEGORY A		CATEGORY B
	CATEGORY B		HIGH
	PRELIMINARY BAT ROOST ASSESSMENT RESULTS		
	CONFIRMED		HIGH
	ROAD SIGN TO BE RETAINED		
	ROAD SIGN TO BE REMOVED		
	ROAD SIGN TO BE REMOVED TO STORE		
	ROAD SIGN TO BE RELOCATED		

KEY:

	TEMPORARY USED LAND. TO BE REINSTATED LAND BACK TO EXISTING.		PERFORATE PAVEMENT - REFER TO APPENDIX 6/7
	TEMPORARY USED LAND. TO BE LEFT IN A TIDY STATE. NO NEED TO REINSTATE		EXCAVATE PAVEMENT FOR FULL DEPTH RECONSTRUCTION
	EXISTING VEGETATION - TO BE RETAINED AS MUCH AS POSSIBLE. EXTENTS OF CLEARANCE IN THESE AREAS IS TO BE AGREED ON SITE WITH OVERSEEING ORGANISATION'S SITE SUPERVISOR		KERBS TO BE REMOVED
	CONSTRUCTION EXCLUSION ZONE - WHEREBY AVOID VEGETATION STRIP ALL TOGETHER AND CONSTRUCTION WORKS ACCESS IS EXCLUDED		TREE PROTECTION FENCING. REFER TO CEMP FOR THE MEASURES REQUIRED TO PROTECT THESE AREAS
	RESTRICTED WORKING ZONE - WHEREBY EXISTING VEGETATION IS ONLY STRIPPED WHERE ABSOLUTELY NECESSARY. WORKS WITHIN THESE AREAS TO BE SUBJECT TO TASK/LOCATION SPECIFIC ARBORICULTURAL METHOD STATEMENT. THE AMS FOR EACH TO BE DEVELOPED DURING CONSTRUCTION PLANNING. THE WORK METHODOLOGY IS TO BE AGREED WITH THE EcOW/ ARBORICULTURIST. TREE PROTECTION FENCING REQUIREMENTS TO THESE AREAS TO BE AGREED WITH ARBORICULTURIST AND EcOW ON SITE.		PLANE WEARING COURSE UP TO 40mm DEEP
	ROOT PROTECTION AREA - INDICATIVE LOCATION ONLY		PLANE 300mm WIDE x 100mm DEEP KEY
			GENERAL SITE CLEARANCE
			STRUCTURAL SITE CLEARANCE
			VISIBILITY SITE CLEARANCE - REMOVAL OF VEGETATION TO A HEIGHT OF 100mm