

SAFETY, HEALTH AND ENVIRONMENTAL INFORMATION	
IN ADDITION TO THE HAZARDS/RISKS NORMALLY ASSOCIATED WITH THE TYPES OF WORK DETAILED ON THIS DRAWING, NOTE THE FOLLOWING	
<b>CONSTRUCTION</b>	C1. EXISTING SERVICES ALONG FONTWELL AVENUE
<b>MAINTENANCE / CLEANING</b>	M1. NONE IDENTIFIED
<b>DECOMMISSIONING / DEMOLITION</b>	D1. NONE IDENTIFIED
IT IS ASSUMED THAT ALL WORKS WILL BE CARRIED OUT BY A COMPETENT CONTRACTOR WORKING WHERE APPROPRIATE, TO AN APPROVED METHOD STATEMENT	

- NOTES:**
- ALL DIMS IN METRES UNLESS OTHERWISE STATED.
  - ALL TIMBER FENCE POSTS, TO HAVE CONCRETE FOUNDATIONS IN ACCORDANCE WITH HCD H3
  - WHERE THE FENCE FORMS A BOUNDARY BETWEEN THE HIGHWAY AND PRIVATE PROPERTY, THE RAILS SHALL BE FIXED TO THE PRIVATE PROPERTY SIDE, UNLESS OTHERWISE STATED.
- KEY:**
- PROPOSED RED LINE BOUNDARY AND PROPOSED HIGHWAY BOUNDARY
  - PROPOSED POST AND THREE RAIL MCHW H15 AND HEDGE. REFER TO LANDSCAPING DRAWINGS A29-CAP-HPN-00-DR-C-0239 FOR HEDGE DETAILS
  - 3.0m ACOUSTIC FENCING REFER TO DRG A29-CAP-HPN-00-DR-C-0183 AND 184 FOR DETAILS
  - GATE REFER TO MCHW H17 GATE NO.1 WIDTH 4.5M, HEIGHT 1.175M GATE NO.2 WIDTH 4.5M, HEIGHT 1.175M GATE NO.3 WIDTH 4.5M, HEIGHT 1.175M
  - FT1 BADGER MESH FENCING, TO COMPLY TO MCHW H46 MESH TO BE BURIED 300MM DEEP AND RETURNED 300MM AND FIXED TO POST AND THREE RAIL FENCE. THE FENCING TO EXTEND AS SHOWN ON THE PLAN EITHER SIDE OF THE WILDLIFE CROSSING POINT
  - PROPOSED POST AND THREE RAIL MCHW H15
  - PROPOSED CLOSED BOARD FENCE PANELS TO MATCH EXISTING
  - HALO SITE PROPOSED FENCING CLOSE BOARD FENCE PANELS WITH GREEN MESH SECURITY FENCE TO MATCH EXISTING HALO FENCING.
  - EXISTING FENCING 1.8M CLOSE BOARD FENCE PANELS INC GRAVEL BOARD WITH 2.4M CENTRE OF CONCRETE POSTS 2.3M GREEN MESH SECURITY FENCE PANELS WITH 3.3M CENTRE OF GREEN METAL POST. SUPPLIER PROCTER - PRO-MESH PANEL FENCING SYSTEMS

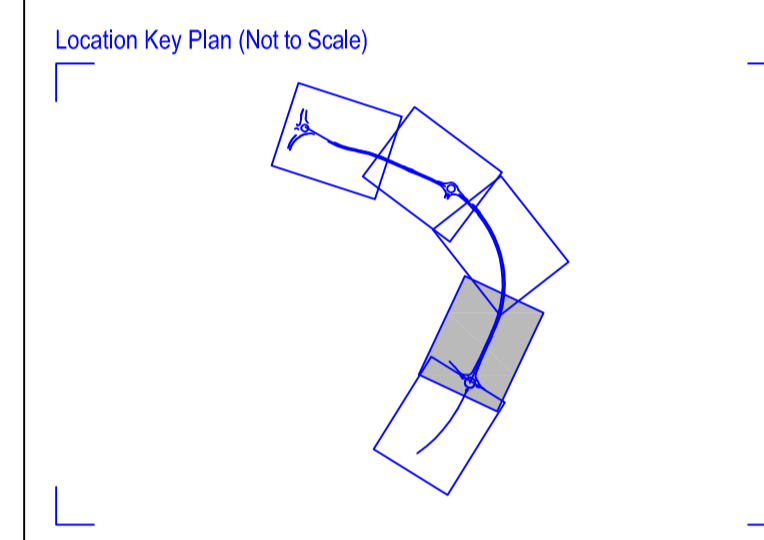

Rev	Drawn	Checked	App'd	Description	Date
P01	KS	KS	AB	FIRST ISSUE	05.05.21

Purpose of Issue  
**For Planning** **S0**

Classification  
**Public**

Client

Project  
**A29 Realignment Scheme**

Drawing  
**Fencing Layout**  
**Sheet 4 of 5**

Scale @ A1	Drawn	Checked	Approved
1:500	KS	KS	AB

Project No. **CS099505** Date **05-05-21**

Drawing Identifier  
Project - Originator - Zone - Level - File Type - Role - Number  
**A29-CAP-HPN-00-DR-C-0261** BS1192 Compliant revision **P01**

**CAPITA**

Capita House, Wood Street, East Grinstead, RH19 1UU  
01342 327161  
www.capitaproperty.co.uk  
Capita Property and Infrastructure Ltd.

**SETTING OUT POINT COORDINATES (SOP)**

POINT No.	X	Y
1	495200.6657	105197.6012
2	495185.5513	105203.9286
3	495178.4279	105186.7533
4	495190.6870	105181.6467
5	495194.8053	105178.9020
6	495186.4717	105162.4470
7	495184.5006	105159.9303
8	495182.3789	105158.2545
9	495178.8530	105180.5191