

SETTING OUT POINT COORDINATES (SOP)		
POINT No.	X	Y
1	495276.5550	105607.8689
2	495277.9489	105604.8123
3	495283.7417	105601.0369
4	495287.2410	105592.0136
5	495281.9999	105578.7825
6	495369.5741	105695.4075
7	495350.7149	105702.0655
8	495331.8556	105708.7235
9	495312.9964	105715.3815
10	495294.1372	105722.0395
11	495255.9229	105735.5488
12	495237.0649	105742.2099
13	495218.2070	105748.8709

SAFETY, HEALTH AND ENVIRONMENTAL INFORMATION

IN ADDITION TO THE HAZARDS/RISKS NORMALLY ASSOCIATED WITH THE TYPES OF WORK DETAILED ON THIS DRAWING, NOTE THE FOLLOWING

CONSTRUCTION
C1. NONE IDENTIFIED.

MAINTENANCE / CLEANING
M1. NONE IDENTIFIED

DECOMMISSIONING / DEMOLITION
D1. NONE IDENTIFIED

IT IS ASSUMED THAT ALL WORKS WILL BE CARRIED OUT BY A COMPETENT CONTRACTOR WORKING, WHERE APPROPRIATE, TO AN APPROVED METHOD STATEMENT

- NOTES:**
- ALL DIMS IN METRES UNLESS OTHERWISE STATED.
 - ALL TIMBER FENCE POSTS, TO HAVE CONCRETE FOUNDATIONS IN ACCORDANCE WITH HCD H3
 - WHERE THE FENCE FORMS A BOUNDARY BETWEEN THE HIGHWAY AND PRIVATE PROPERTY, THE RAILS SHALL BE FIXED TO THE PRIVATE PROPERTY SIDE, UNLESS OTHERWISE STATED.
- KEY:**
- PROPOSED RED LINE BOUNDARY AND PROPOSED HIGHWAY BOUNDARY
 - PROPOSED POST AND THREE RAIL MCHW H15 AND HEDGE. REFER TO LANDSCAPING DRAWING A29-CAP-HPN-00-DR-C-0239 FOR HEDGE DETAILS
 - 3.0m ACOUSTIC FENCING REFER TO DRG A29-CAP-HPN-00-DR-C-0183 AND 184 FOR DETAILS
 - GATE REFER TO MCHW H17 GATE NO.1 WIDTH 4.5M, HEIGHT 1.175M GATE NO.2 WIDTH 4.5M, HEIGHT 1.175M GATE NO.3 WIDTH 4.5M, HEIGHT 1.175M
 - FT 1 BADGER MESH FENCING, TO COMPLY TO MCHW H46 MESH TO BE BURIED 300MM DEEP AND RETURNED 300MM AND FIXED TO POST AND THREE RAIL FENCE. THE FENCING TO EXTEND AS SHOWN ON THE PLAN EITHER SIDE OF THE WILDLIFE CROSSING POINT
 - PROPOSED POST AND THREE RAIL MCHW H15
 - PROPOSED CLOSE BOARD FENCE PANELS TO MATCH EXISTING

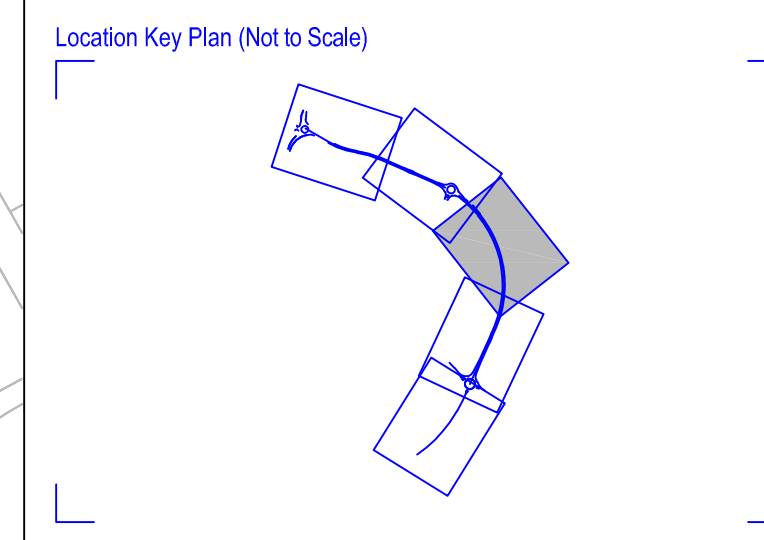
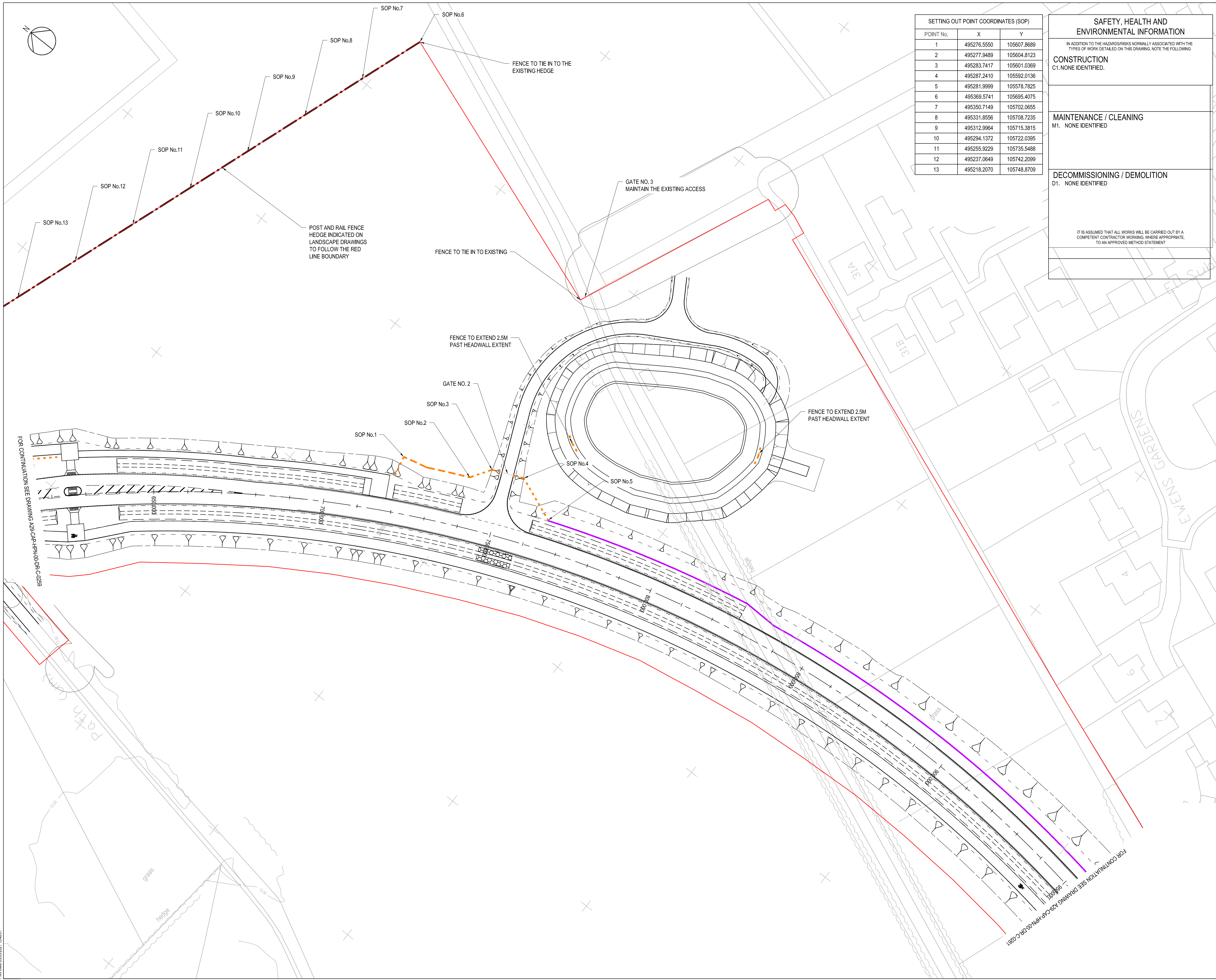

Rev	KS	KS	AB	First Issue	05.05.21
Rev	Drawn	Checked	App'd	Description	Date

Purpose of Issue
For Planning **S0**

Classification
Public

Client



Project
A29 Realignment Scheme

Drawing
Fencing Layout
Sheet 3 of 5

Scale @ A1	Drawn	Checked	Approved
1:500	KS	KS	AB

Project No.	Date
CS099505	05-05-21

Drawing Identifier
Project - Originator - Zone - Level - File Type - Role - Number
A29-CAP-HPN-00-DR-C-0260 **P01**

CAPITA

Capita House, Wood Street, East Grinstead, RH19 1UU
01342 327161
www.capitaproperty.co.uk
Capita Property and Infrastructure Ltd.

Print Date: 05/05/2021 14:48:01